

KR

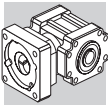

BONFIGLIOLI



SYMBOLS, UNITS AND DEFINITIONS

Values depending on the **APPLICATION**

term	u.m.	definition
A₂	[N]	Thrust force on output shaft
R₂	[N]	Radial force on output shaft
ED	[min]	Loading time
ED%	[%]	Loading time %
L_{10h}	[h]	Bearings' basic rating life
M_{1PEAK}	[Nm]	Maximum input torque (usually motor)
M_{2(1) ... M_{2(n)}}	[Nm]	Output torque at each of the time periods t ₁ ... t _n
M_{2EQU}	[Nm]	Equivalent output torque
M_{2MAX}	[Nm]	Maximum output torque in case of emergency
n_{2(1) ... n_{2(n)}}	[min ⁻¹]	Output speed based on the time periods t ₁ ... t _n
n_{2EQU}	[min ⁻¹]	Equivalent output speed
n_{2MAX}	[min ⁻¹]	Maximum output speed
n₂	[min ⁻¹]	Output speed
T	[°C]	Ambient temperature
t₁ ... t_n	[s]	Time periods of motion
t_Σ	[s]	Cycle duration including pause
Z	[1/h]	Cycle number per hour

Values depending on the **GEAR DRIVE SELECTION**

term	u.m.	definition
A_n	[N]	Admissible thrust force
A_{n'}	[N]	Thrust force acting simultaneously with the rated radial force
R_n	[N]	Admissible radial force at midpoint of output shaft
C_t	$\left[\frac{\text{Nm}}{\text{arcmin}} \right]$	Torsional stiffness
f_n	—	Speed factor
f_z	—	Cycle factor
f_T	—	Temperature correction factor
i	—	Gearbox ratio
J_G	[kgm ²]	Mass moment of inertia of the gearhead
L_Z	[mm]	Factor for bearing's lifetime calculation
M_{T2ref}	[Nm]	Reference tilting moment
C_B	[Nm]	Constant for bearing's lifetime calculation
p	—	Bearing lifetime exponent
M_{n2}	[Nm]	Rated output torque
M_{a2}	[Nm]	Maximum acceleration output torque
M_{p2}	[Nm]	Emergency stop output torque
n_{1ref}	[min ⁻¹]	Reference input speed of the gearhead
n_{1max}	[min ⁻¹]	Maximum momentary input speed. The speed the unit can be driven at occasionally and in non-repetitive conditions. For cycle duty type S5, it cannot be applied continuously for more than 30 seconds
η	[%]	Gear efficiency
φ_S	[arcmin]	Standard backlash is calculated in static conditions and with the application of a torque equal to 2% of the gear unit rated torque
φ_R	[arcmin]	Reduced backlash is calculated in static conditions and with the application of a torque equal to 2% of the gear unit rated torque

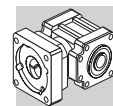

SUMMARY

Chapter Contents



1 General information	2
1.1 Features of KR series	2
1.2 Versions	3
1.3 Mounting positions	3
1.4 Coordinated shaft rotation	3
1.5 Selecting the gear unit	4
1.6 Ordering code	6
2 Technical specifications	7
3 Mass moment of inertia	8
3.1 KR 10...KR 40 with standard ball bearings	8
3.2 KR 20...KR 40 with taper roller bearings (HDB option)	9
4 Dimensions	10
KR 10	10
KR 20	12
KR 30	14
KR 40	16
4.1 Gearbox without motor adapter - FM	18
4.2 Machine shaft	19

Revisions

Refer to page 20 for the catalogue revision index.

Visit www.tecnoingranaggi.it to search for catalogues with up-to-date revisions.

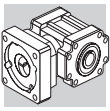

1 GENERAL INFORMATION

1.1 FEATURES OF KR SERIES

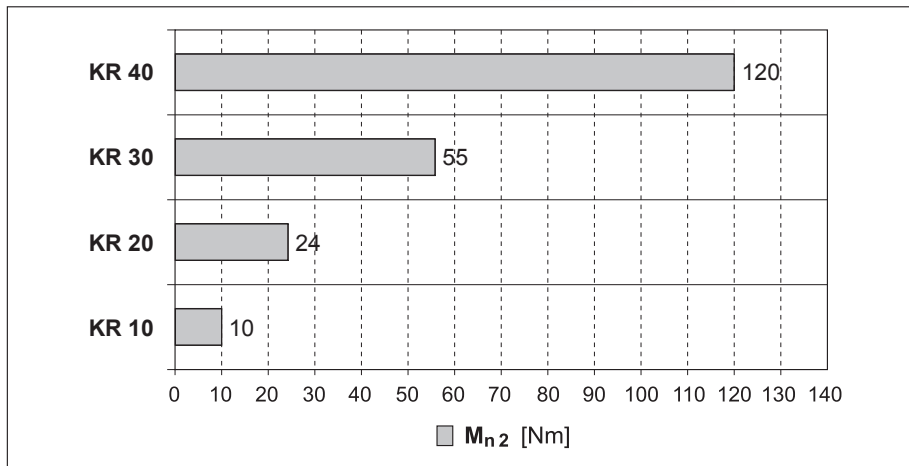
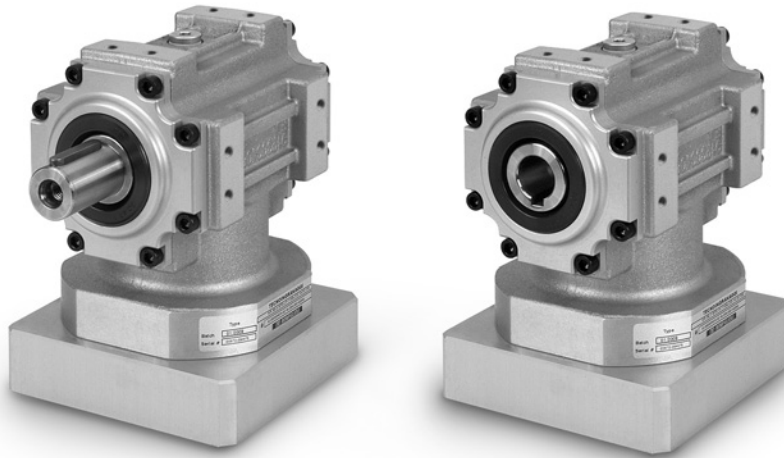

Bevel helical units type KR, manufactured under the most stringent quality specifications, are designed for dynamic and accurate applications where light weight and space effectiveness are a factor.

Many options can be selected from the catalogue as far as motor adapters and output shaft configurations that facilitate the installation on the driven equipment.

- Available in one only backlash option ($\psi_s = 8'$)
- Single reduction: ratios $i = 1, 2, 5$
- Radial ball bearings are of standard supply, while taper roller bearings can be optionally specified for particularly demanding loading conditions
- Degree of protection IP65
- Oil seals from Viton® compound as standard
- Max. noise level $L_p \leq 70$ dB(A) @ $n_1 = 3000$ min⁻¹
- Units are factory charged with synthetic lubricant suitable for operation at ambient temperatures in the range 0°...40°C. The lubricant quantity is affected by mounting position, that therefore will have to be specified at the time of ordering. In the absence of contamination lubricant does not require periodical changes.
The type of lubricant, whether grease or oil, depends on type of duty, as charted below:

duty	KR 10 ... KR 40
S1 (continuous)	synthetic oil viscosity ISO VG 220
S5 (intermittent)	NLGI grease consistency 00

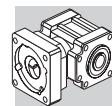

1.2 VERSIONS

Parallel shaft

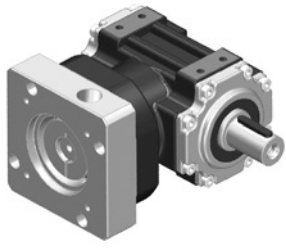
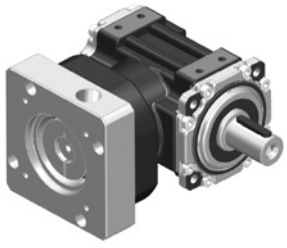
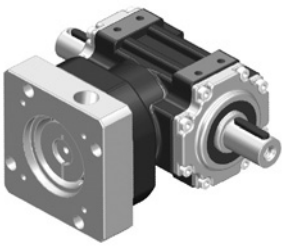
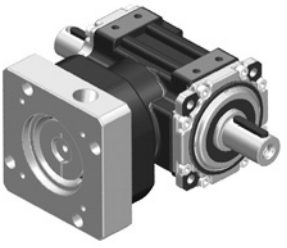
LP	LPF	LD	LDF
			
single extension	single extension + flange	double extension	double extension + flange

Hollow shaft

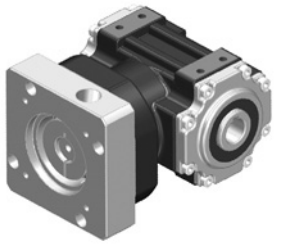
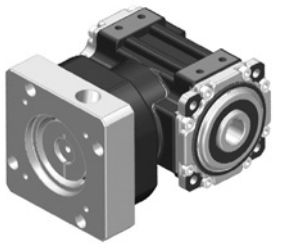
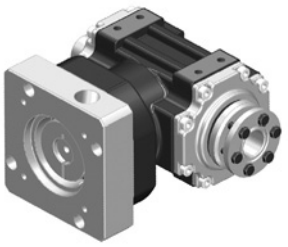
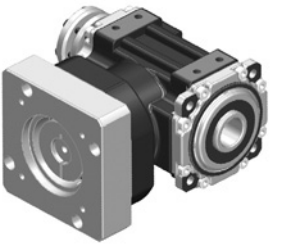
H	HF	S	SF
			
keyed (KR 30...KR 40)	keyed shaft + flange (KR 30...KR 40)	with shrink disc	with shrink disc + flange

1.3 MOUNTING POSITIONS

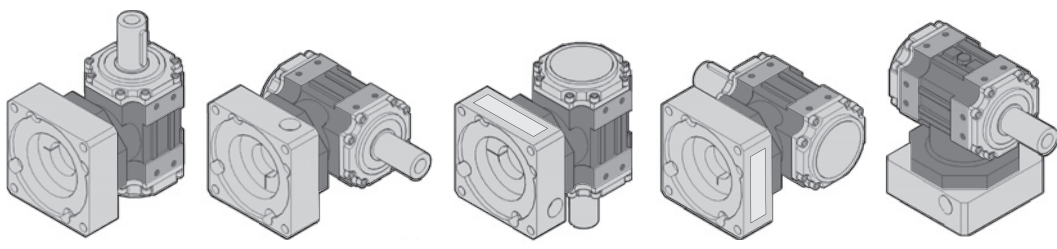
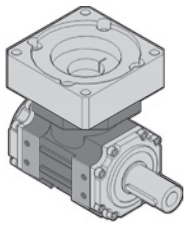
U	VA
	

1.4 COORDINATED SHAFT ROTATION

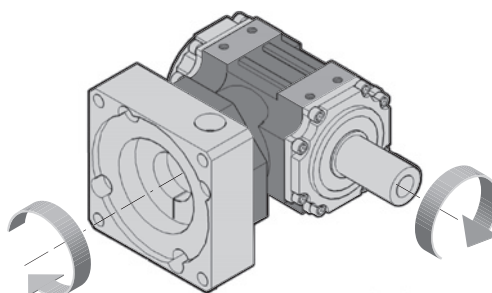

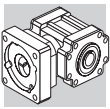

1.5 SELECTING THE GEAR UNIT

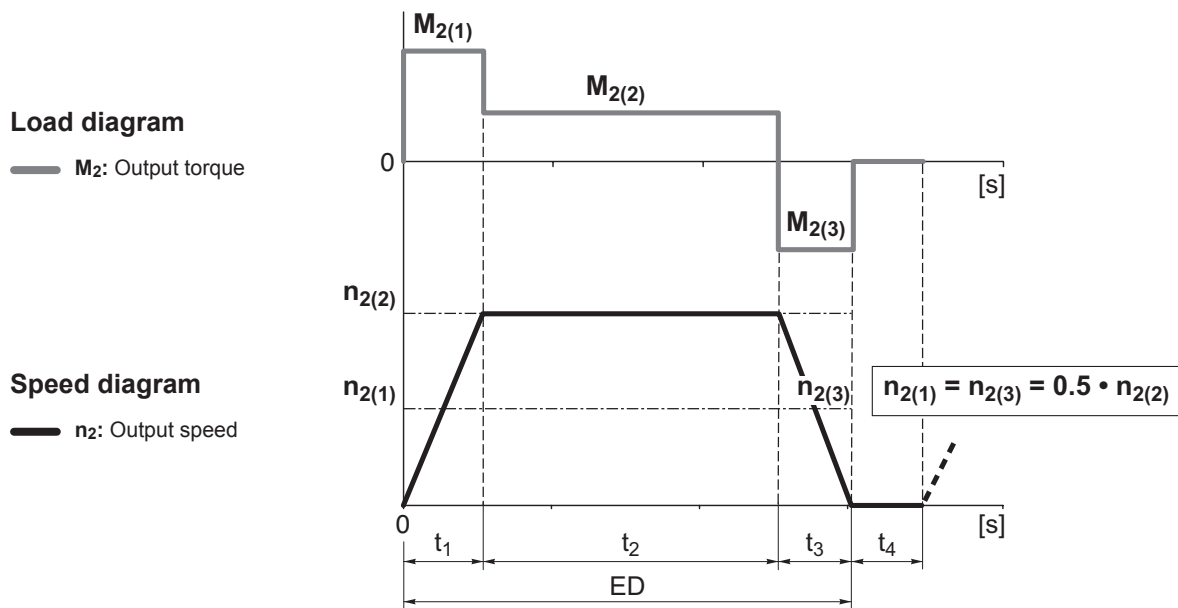

Ratio	i	—	$i = \frac{n_1}{n_2}$	①														
Equivalent output torque	M_{2EQU}	[Nm]	$M_{2EQU} = \sqrt[3]{\frac{n_{2(1)} \cdot t_1 \cdot M_{2(1)} ^3 + \dots + n_{2(n)} \cdot t_n \cdot M_{2(n)} ^3}{n_{2(1)} \cdot t_1 + \dots + n_{2(n)} \cdot t_n}}$	②.1														
Equivalent output speed	n_{2EQU}	[min ⁻¹]	$n_{2EQU} = \frac{n_{2(1)} \cdot t_1 + n_{2(2)} \cdot t_2 + \dots + n_{2(n)} \cdot t_n}{t_1 + t_2 + \dots + t_n}$	②.2														
Speed factor	f_n	—	If $n_{2EQU} \cdot i \leq n_{1ref} \Rightarrow f_n = 1$ If $n_{2EQU} \cdot i > n_{1ref} \Rightarrow f_n = \sqrt[3]{\frac{n_{2EQU} \cdot i}{n_{1ref}}}$	②.3														
Loading time	ED%	[%]	$ED\% = \frac{t_1 + t_2 + \dots + t_n}{t_\Sigma} \cdot 100$	③														
Loading time	ED	[min]	$ED = t_1 + t_2 + \dots + t_n$															
Cycle number	Z	[1/h]	$Z = \frac{3600}{t_\Sigma}$	④														
Cycle factor	f_z	—	<table border="1" style="width: 100%; text-align: center;"> <thead> <tr> <th>Z</th> <th>f_z</th> </tr> </thead> <tbody> <tr> <td>$Z \leq 1000$</td> <td>1.00</td> </tr> <tr> <td>$1000 < Z \leq 1500$</td> <td>1.25</td> </tr> <tr> <td>$1500 < Z \leq 2500$</td> <td>1.50</td> </tr> <tr> <td>$2500 < Z \leq 4000$</td> <td>1.75</td> </tr> <tr> <td>$4000 < Z \leq 6000$</td> <td>2.00</td> </tr> <tr> <td>$Z > 6000$</td> <td>contact us</td> </tr> </tbody> </table>	Z	f_z	$Z \leq 1000$	1.00	$1000 < Z \leq 1500$	1.25	$1500 < Z \leq 2500$	1.50	$2500 < Z \leq 4000$	1.75	$4000 < Z \leq 6000$	2.00	$Z > 6000$	contact us	⑤.1
Z	f_z																	
$Z \leq 1000$	1.00																	
$1000 < Z \leq 1500$	1.25																	
$1500 < Z \leq 2500$	1.50																	
$2500 < Z \leq 4000$	1.75																	
$4000 < Z \leq 6000$	2.00																	
$Z > 6000$	contact us																	
Temperature factor	f_T	—	If $T \leq 20^\circ\text{C} \Rightarrow f_T = 1$ If $T > 20^\circ\text{C} \Rightarrow f_T = 1 + \frac{T - 20^\circ\text{C}}{100^\circ\text{C}}$	⑤.2														
Maximum input torque	M_{1PEAK}	[Nm]	a) maximum possible application torque b) limited motor torque by inverter c) maximum motor torque	⑤.3														

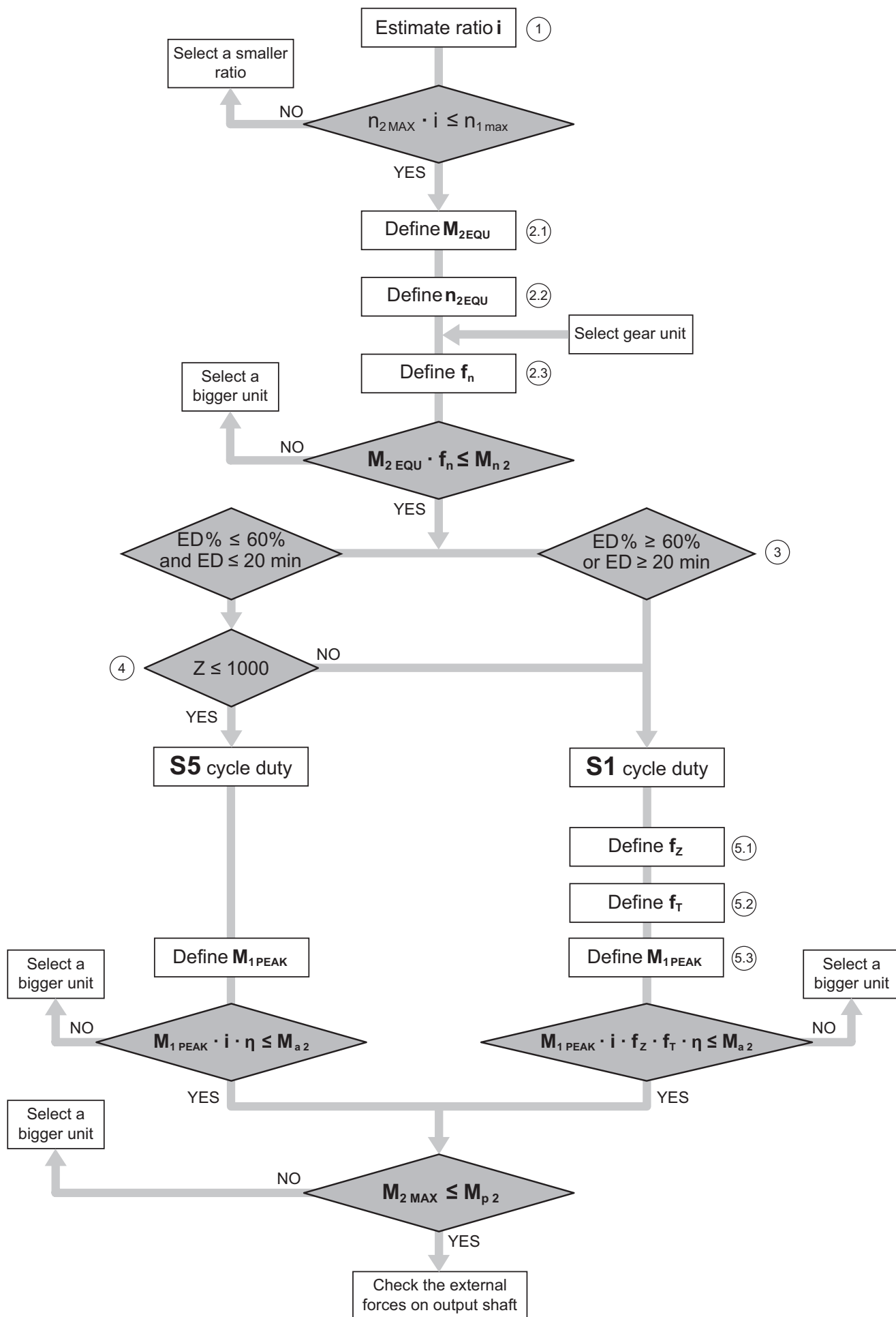
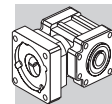

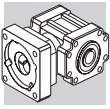

1.6 ORDERING CODE

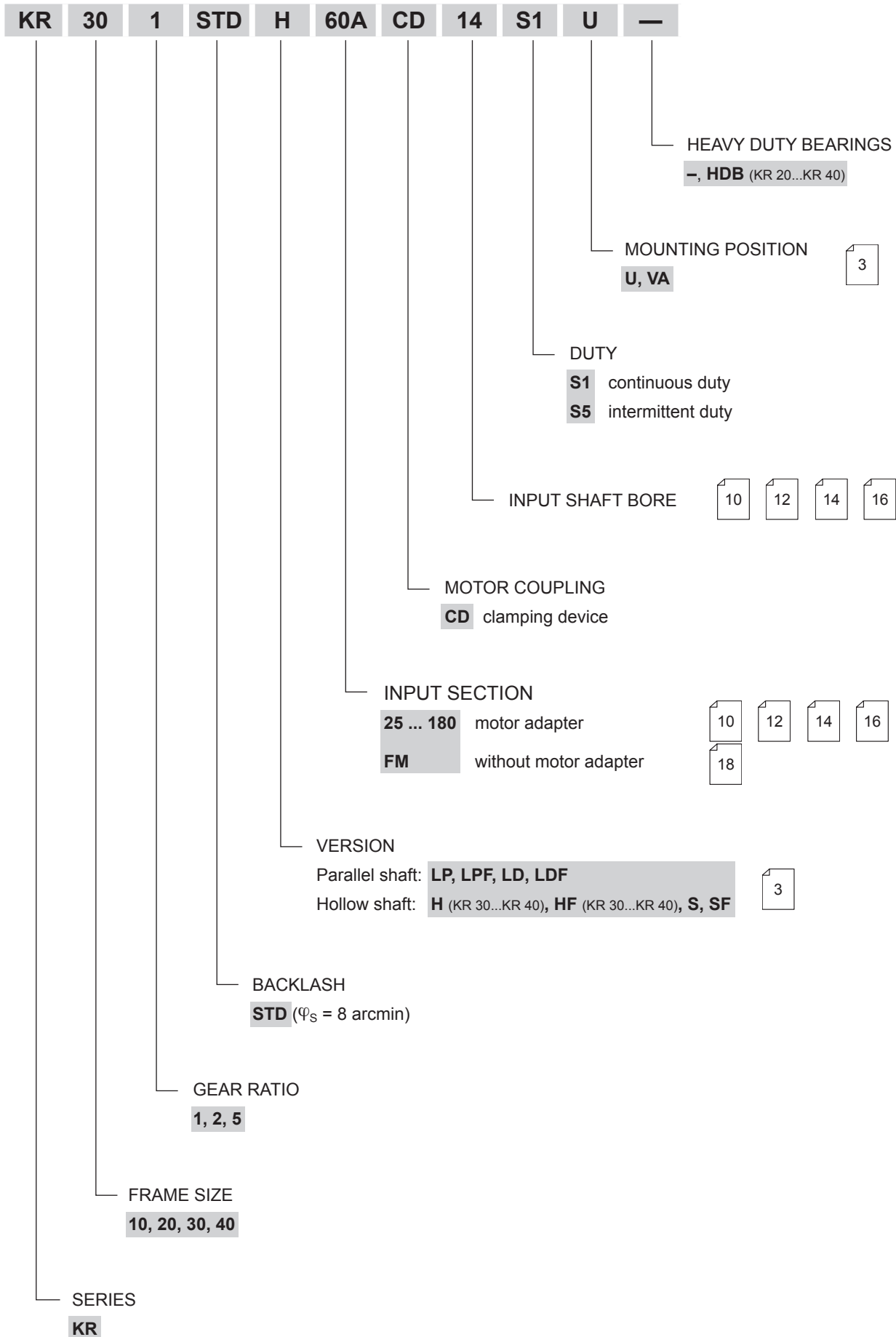

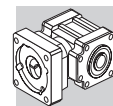

2 TECHNICAL SPECIFICATIONS

KR 10							
	M_{n2} [Nm]	M_{a2} [Nm]	M_{p2} [Nm]	n_{1ref} [min ⁻¹]	n_{1max} [min ⁻¹]	φ_s [arcmin]	η %
i = 1	10	14	20	1200	4000		
i = 2	7	10	15	2400	5000	8'	97
i = 5	3	4	6	3000	5000		

KR 20							
	M_{n2} [Nm]	M_{a2} [Nm]	M_{p2} [Nm]	n_{1ref} [min ⁻¹]	n_{1max} [min ⁻¹]	φ_s [arcmin]	η %
i = 1	24	35	50	1200	4000		
i = 2	15	21	30	2400	5000	8'	97
i = 5	10	13	20	3000	5000		

KR 30							
	M_{n2} [Nm]	M_{a2} [Nm]	M_{p2} [Nm]	n_{1ref} [min ⁻¹]	n_{1max} [min ⁻¹]	φ_s [arcmin]	η %
i = 1	55	75	110	1000	3500		
i = 2	37	52	75	2000	4500	8'	97
i = 5	22	29	45	2800	4500		

KR 40							
	M_{n2} [Nm]	M_{a2} [Nm]	M_{p2} [Nm]	n_{1ref} [min ⁻¹]	n_{1max} [min ⁻¹]	φ_s [arcmin]	η %
i = 1	120	170	240	800	3500		
i = 2	85	120	170	1600	4500	8'	97
i = 5	45	60	90	2500	4500		

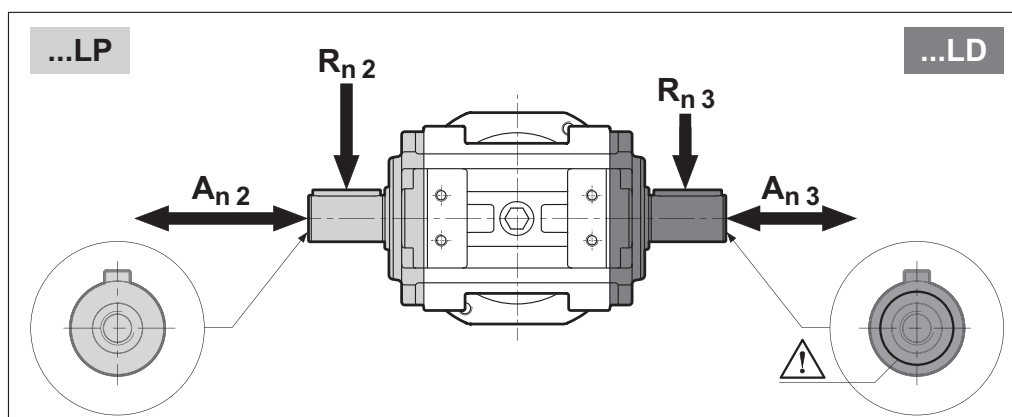

		R_{n2} [N]	A_{n2} [N]	$A_{n'2}$ [N]	R_{n3} [N]	A_{n3} [N]	$A_{n'3}$ [N]
KR 10		1000	—	200	500	—	100
KR 20		1500	—	300	750	—	150
	HDB	3000	1500	600	3000	1500	600
KR 30		2000	—	400	1000	—	200
	HDB	4000	2000	800	4000	2000	800
KR 40		3000	—	600	1500	—	300
	HDB	5500	2750	1100	5500	2750	1100

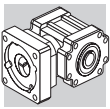

3 MASS MOMENT OF INERTIA

3.1 KR 10...KR 40 with standard ball bearings

KR 10			
		J_G [kgcm ²]	
		$6 \leq D \leq 9.52$	$10 \leq D \leq 14$
$i = 1$	S, SF	0.52	0.52
	LP, LPF	0.38	0.38
	LD, LDF	0.39	0.39
$i = 2$	S, SF	0.27	0.29
	LP, LPF	0.24	0.25
	LD, LDF	0.24	0.25
$i = 5$	S, SF	0.20	0.21
	LP, LPF	0.19	0.21
	LD, LDF	0.19	0.21

KR 20			
		J_G [kgcm ²]	
		$8 \leq D \leq 12.7$	$14 \leq D \leq 19.05$
$i = 1$	S, SF	1.61	1.80
	LP, LPF	1.34	1.52
	LD, LDF	1.37	1.55
$i = 2$	S, SF	0.86	1.05
	LP, LPF	0.80	0.98
	LD, LDF	0.80	0.99
$i = 5$	S, SF	0.66	0.84
	LP, LPF	0.64	0.83
	LD, LDF	0.65	0.83

KR 30				
		J_G [kgcm ²]		
		$11 \leq D \leq 12.7$	$14 \leq D \leq 19$	$22 \leq D \leq 24$
$i = 1$	H, HF	4.37	4.45	4.64
	S, SF	5.00	5.08	5.27
	LP, LPF	4.70	4.78	4.97
	LD, LDF	4.63	4.71	4.90
$i = 2$	H, HF	2.04	2.12	2.31
	S, SF	2.20	2.28	2.47
	LP, LPF	2.12	2.20	2.39
	LD, LDF	2.11	2.19	2.37
$i = 5$	H, HF	1.47	1.55	1.74
	S, SF	1.50	1.57	1.76
	LP, LPF	1.48	1.56	1.75
	LD, LDF	1.48	1.56	1.75

KR 40				
		J_G [kgcm ²]		
		$14 \leq D \leq 19$	$22 \leq D \leq 24$	$D = 28$
$i = 1$	H, HF	17.19	17.37	17.77
	S, SF	20.46	20.65	21.05
	LP, LPF	18.21	18.40	18.80
	LD, LDF	18.90	19.08	19.48
$i = 2$	H, HF	4.47	4.65	5.06
	S, SF	5.29	5.47	5.87
	LP, LPF	4.73	4.91	5.31
	LD, LDF	4.90	5.08	5.48
$i = 5$	H, HF	5.23	5.42	5.82
	S, SF	5.36	5.55	5.95
	LP, LPF	5.27	5.46	5.86
	LD, LDF	5.30	5.49	5.89

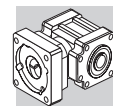

3.2 KR 20...KR 40 with taper roller bearings (HDB option)

KR 20			
		J_G [kgcm ²]	
		$8 \leq D \leq 9.52$	$10 \leq D \leq 14$
i = 1	S, SF	1.87	2.06
	LP, LPF	1.60	1.78
	LD, LDF	1.62	1.81
i = 2	S, SF	0.93	1.12
	LP, LPF	0.86	1.05
	LD, LDF	0.87	1.05
i = 5	S, SF	0.67	0.85
	LP, LPF	0.66	0.84
	LD, LDF	0.66	0.84

KR 30				
		J_G [kgcm ²]		
		$11 \leq D \leq 12.7$	$14 \leq D \leq 19$	$22 \leq D \leq 24$
i = 1	H, HF	5.48	5.56	5.75
	S, SF	6.11	6.19	6.38
	LP, LPF	5.81	5.89	6.08
	LD, LDF	5.74	5.82	6.01
i = 2	H, HF	2.92	3.00	3.19
	S, SF	3.08	3.16	3.35
	LP, LPF	3.01	3.09	3.27
	LD, LDF	2.99	3.07	3.26
i = 5	H, HF	1.51	1.59	1.78
	S, SF	1.54	1.62	1.81
	LP, LPF	1.53	1.61	1.80
	LD, LDF	1.53	1.60	1.79

KR 40				
		J_G [kgcm ²]		
		$14 \leq D \leq 19$	$22 \leq D \leq 24$	D = 28
i = 1	H, HF	18.82	19.01	19.41
	S, SF	22.10	22.28	22.69
	LP, LPF	19.85	20.04	20.44
	LD, LDF	20.53	20.72	21.12
i = 2	H, HF	4.88	5.06	5.47
	S, SF	5.70	6.28	6.28
	LP, LPF	5.13	5.72	5.72
	LD, LDF	5.31	5.89	5.89
i = 5	H, HF	5.30	5.48	5.89
	S, SF	5.43	6.02	6.02
	LP, LPF	5.34	5.93	5.93
	LD, LDF	5.37	5.95	5.95

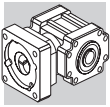

KR 10

4 DIMENSIONS

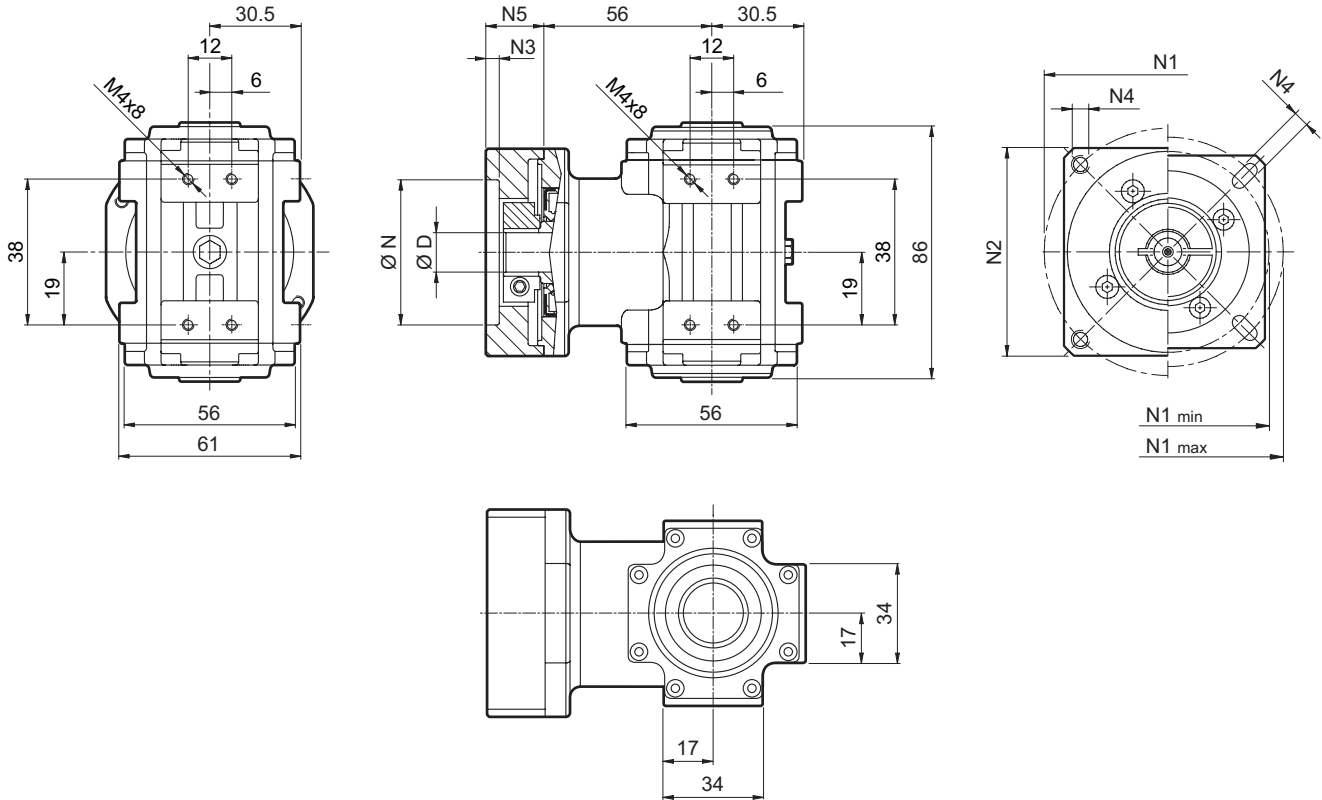

	D											N	N1		N2	N3	N4	N5	L _{max}
	6	6.35	7	8	9	9.52	-	-	-	-	-		min	max					
25AH	6	6.35	7	8	9	9.52	-	-	-	-	-	25	39	56	55	3.5	4.5	25	25
26AH	6	6.35	7	8	9	9.52	-	-	-	-	26	39	56						
28AH	6	6.35	7	8	9	9.52	-	-	-	-	28	39	56						
30AH	6	6.35	7	8	9	9.52	-	-	-	-	30	39	56						
32AH	6	6.35	7	8	9	9.52	-	-	-	-	32	40	56						
34AH	6	6.35	7	8	9	9.52	-	-	-	-	34	42	56						
36AH	6	6.35	7	8	9	9.52	-	-	-	-	36	44	56						
39AH	6	6.35	7	8	9	9.52	-	-	-	-	39	47	56						
40AH	6	6.35	7	8	9	9.52	-	-	-	-	40	48	56						
38A	6	6.35	7	8	9	9.52	10	11	12	12.7	-	38.1	66.6	60	3	M4x10	18	25	
40B	6	6.35	7	8	9	9.52	10	11	12	12.7	-	40	63	60	3	M4x10	18	25	
50A	6	6.35	7	8	9	9.52	10	11	12	12.7	-	50	60	60	3	M4x10	18	25	
50B	6	6.35	7	8	9	9.52	10	11	12	12.7	14	50	65	60	3	M5x12	23	30	
50BH	6	6.35	7	8	9	9.52	10	11	12	12.7	14	50	65	65	3	5	23	30	
50C	6	6.35	7	8	9	9.52	10	11	12	12.7	14	50	70	60	3	M4x10	23	30	
55MH	6	6.35	7	8	9	9.52	10	11	12	12.7	-	55	80	65	2	5.5	16	23	
60A	6	6.35	7	8	9	9.52	10	11	12	12.7	-	60	75	63	3	M5x12	18	25	
60A1	6	6.35	7	8	9	9.52	10	11	12	12.7	14	60	75	63	3	M5x12	23	30	
60B	6	6.35	7	8	9	9.52	10	11	12	12.7	14	60	85	75	3	M5x12	23	30	
60C	6	6.35	7	8	9	9.52	10	11	12	12.7	14	60	90	75	3	M5x12	23	30	
70A	6	6.35	7	8	9	9.52	10	11	12	12.7	14	70	85	75	3	M6x15	23	30	
70B	6	6.35	7	8	9	9.52	10	11	12	12.7	14	70	90	75	3	M5x12	23	30	
73A	6	6.35	7	8	9	9.52	10	11	12	12.7	14	73	98.4	85	3	M5x12	25	32	
80A	6	6.35	7	8	9	9.52	10	11	12	12.7	14	80	100	85	3	M6x15	23	30	

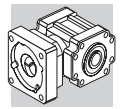

KR 10... S

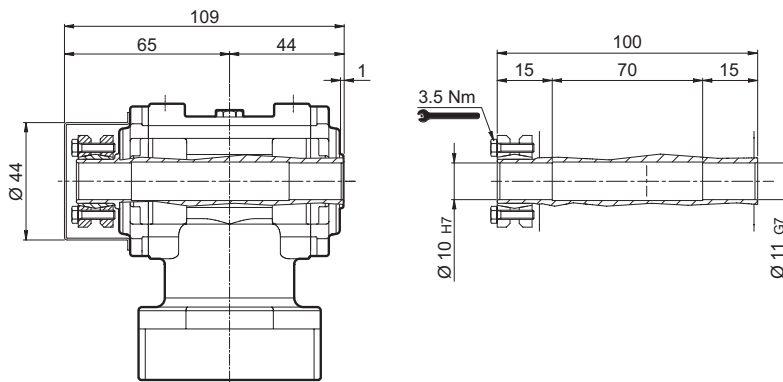

KR 10... SF

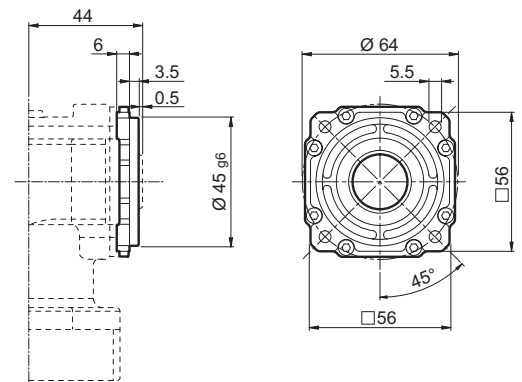

KR 10... LP

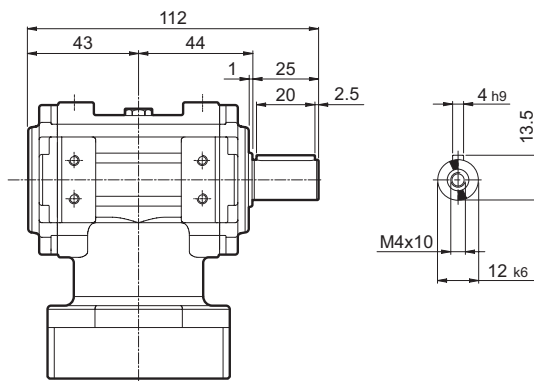

KR 10... LPF

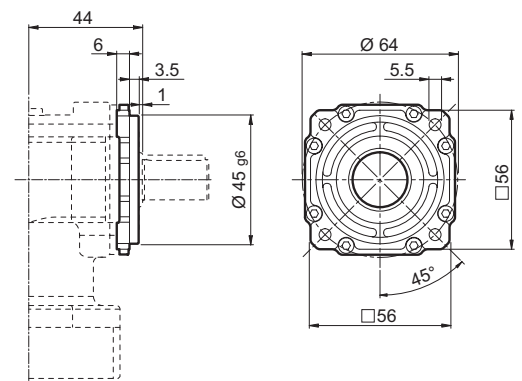

KR 10... LD

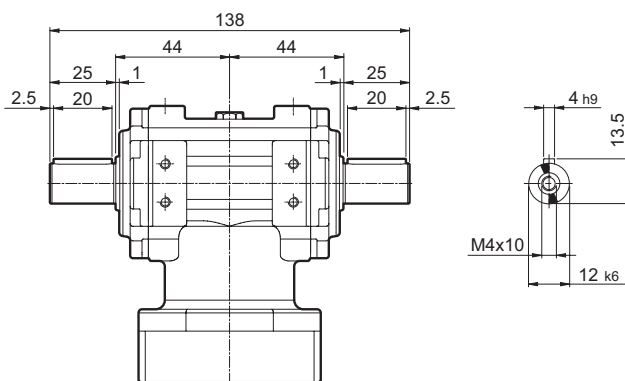

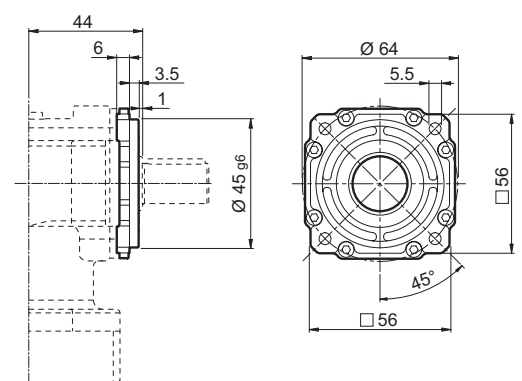

KR 10... LDF

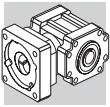

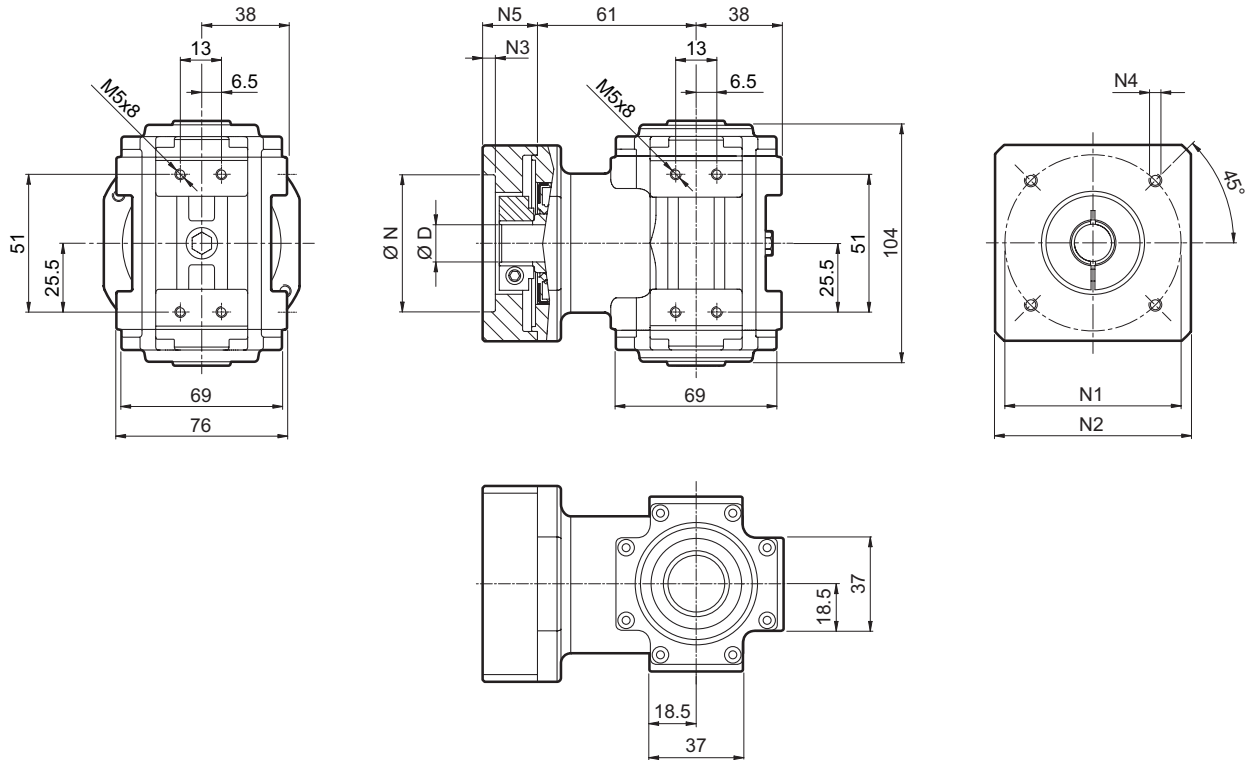

KR 20

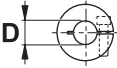
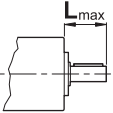

												N	N1	N2	N3	N4	N5		
40B	8	9	9.52	-	-	-	-	-	-	-	-	40	63	80	4	M4x10	34	40	
45A	8	9	9.52	11	12	12.7	-	-	-	-	-	45	63	80	4	M4x10	34	40	
50B	8	9	9.52	11	12	12.7	14	-	-	-	-	50	65	80	4	M5x16	34	40	
50BH	8	9	9.52	11	12	12.7	14	-	-	-	-	50	65	80	4	5.5	34	40	
50C	8	9	9.52	11	12	12.7	14	-	-	-	-	50	70	80	4	M4x10	34	40	
50D	8	9	9.52	11	12	12.7	14	-	-	-	-	50	95	80	4	M6x10	34	40	
55A	8	9	9.52	11	12	12.7	14	15.875	16	17	19	19.05	55.5	127.5	105	4	M6x16	34	40
60A	8	9	9.52	11	12	12.7	14	-	-	-	-	60	75	80	4	M5x16	34	40	
60AH	8	9	9.52	11	12	12.7	14	-	-	-	-	60	75	90	4	5.5	34	40	
60B	8	9	9.52	11	12	12.7	14	15.875	16	-	-	60	85	80	4	M5x16	34	40	
60C	8	9	9.52	11	12	12.7	14	15.875	16	-	-	60	90	80	4	M5x16	34	40	
60MH	8	9	9.52	11	12	12.7	14	15.875	16	17	19	19.05	60	108.5	90	2	6.5	20	26
70A	8	9	9.52	11	12	12.7	14	15.875	16	17	19	19.05	70	85	80	4	M6x20	34	40
70AH	8	9	9.52	11	12	12.7	14	15.875	16	17	19	19.05	70	85	90	4	6.5	34	40
70B	8	9	9.52	11	12	12.7	14	15.875	16	17	19	19.05	70	90	80	4	M5x16	34	40
73A	8	9	9.52	11	12	12.7	14	-	-	-	-	73	98.4	85	4	M5x16	34	40	
78AH	8	9	9.52	11	12	12.7	14	-	-	-	-	78	63.5	90	4	6.5	34	40	
80A	8	9	9.52	11	12	12.7	14	15.875	16	17	19	19.05	80	100	90	4	M6x16	34	40
95A	8	9	9.52	11	12	12.7	14	15.875	16	17	19	19.05	95	115	100	4	M8x20	34	40
95B	8	9	9.52	11	12	12.7	14	15.875	16	17	19	19.05	95	130	115	4	M8x20	34	40
110A	8	9	9.52	11	12	12.7	14	15.875	16	17	19	19.05	110	130	115	4	M8x20	34	40
110B	8	9	9.52	11	12	12.7	14	15.875	16	17	19	19.05	110	145	120	6.5	M8x20	44	50
110B1	8	9	9.52	11	12	12.7	14	15.875	16	17	19	19.05	110	145	120	6.5	M8x20	54	60

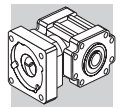

KR 20... S

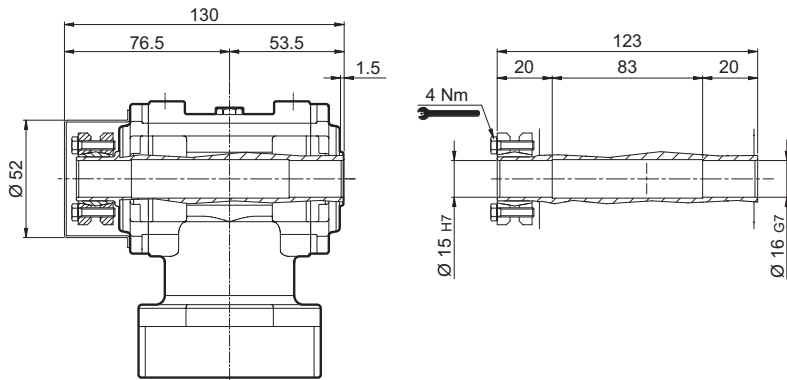

KR 20... SF

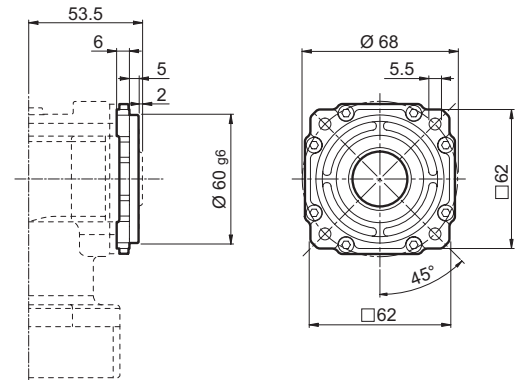

KR 20... LP

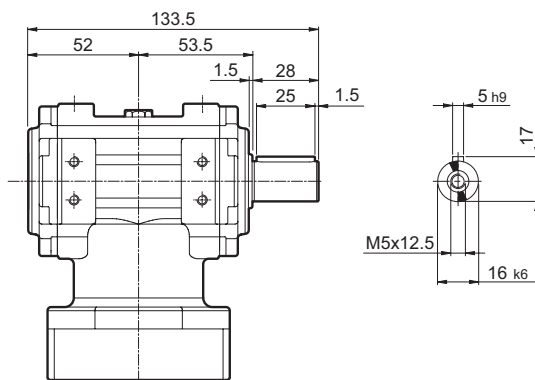

KR 20... LPF

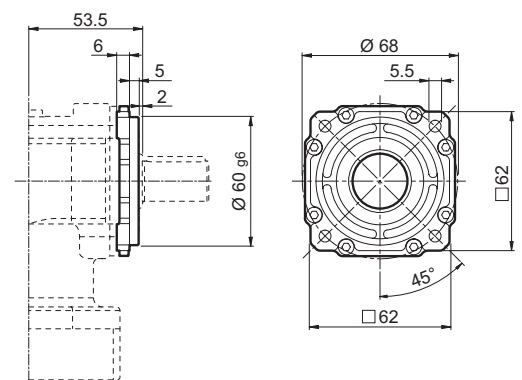

KR 20... LD

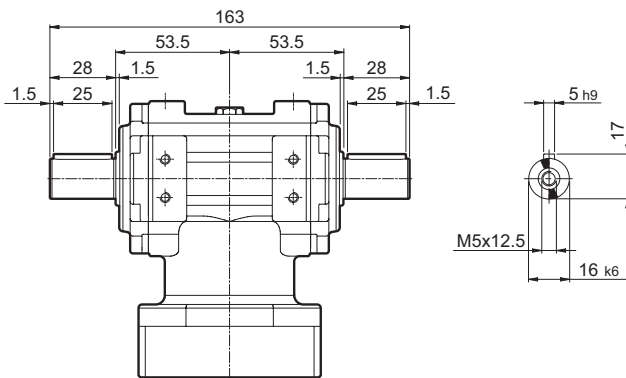

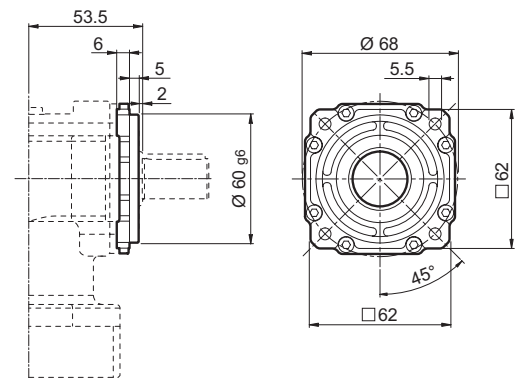

KR 20... LDF

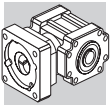

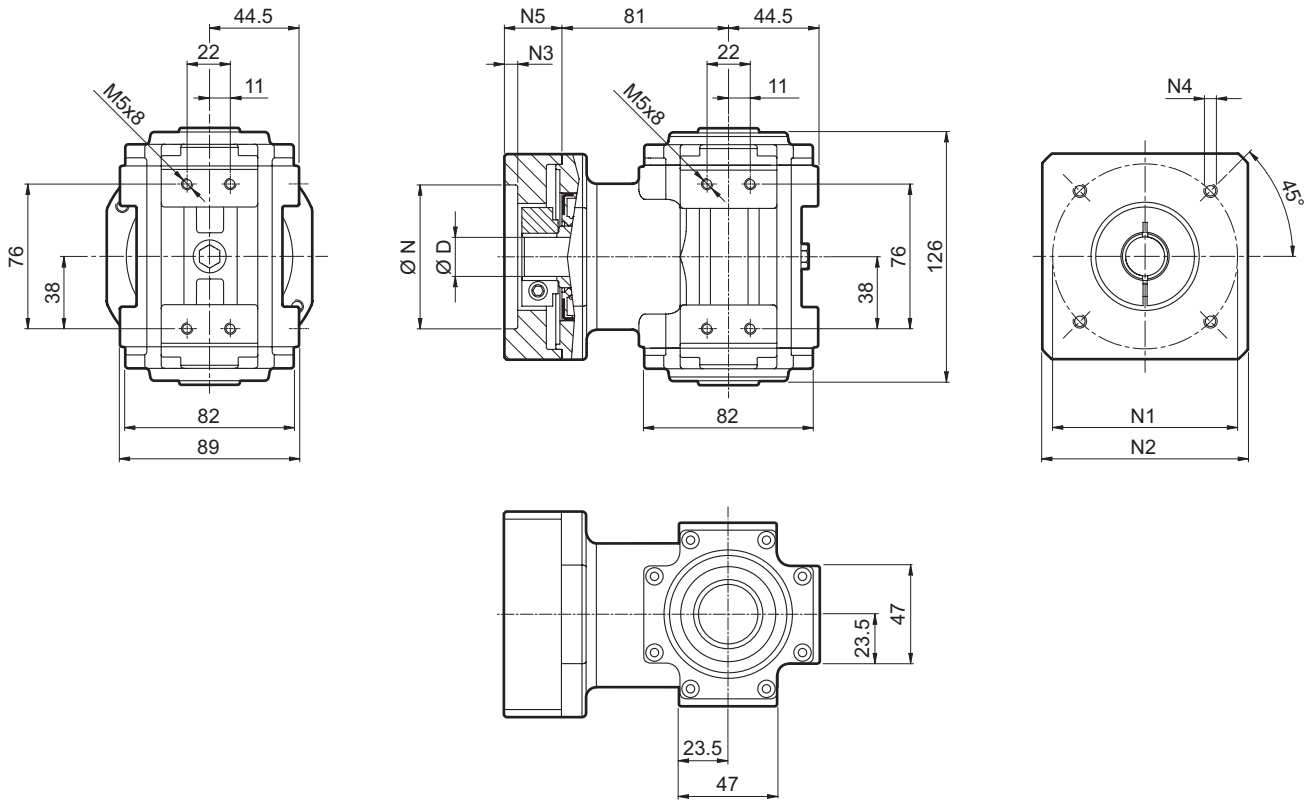

KR 30

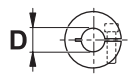
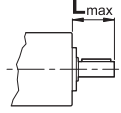

											N	N1	N2	N3	N4	N5	
50D	11	12	12.7	14	15	15.875	16	19	-	-	50	95	100	5	M6x14	28	40
55A	11	12	12.7	14	15	15.875	16	19	-	-	55.5	125.7	105	5	M6x16	28	40
60A	11	12	12.7	14	15	15.875	16	19	-	-	60	75	100	5	M5x14	28	40
60AH	11	12	12.7	14	15	15.875	16	19	-	-	60	75	100	5	6.5	33	40
60B	11	12	12.7	14	15	15.875	16	19	-	-	60	85	100	6.5	M5x14	28	40
70A	11	12	12.7	14	15	15.875	16	19	-	-	70	85	100	5	M6x14	28	40
70AH	11	12	12.7	14	15	15.875	16	19	-	-	70	85	100	5	6	33	40
70B	11	12	12.7	14	15	15.875	16	19	-	-	70	90	100	5	M5x12	28	40
80A	11	12	12.7	14	15	15.875	16	19	-	-	80	100	100	5	M6x16	28	40
80AH	11	12	12.7	14	15	15.875	16	19	-	-	80	100	100	5	6.5	28	40
95A	11	12	12.7	14	15	15.875	16	19	-	-	95	115	100	5	M8x18	28	40
95A1	11	12	12.7	14	15	15.875	16	19	22	24	95	115	100	5	M8x18	38	50
95B	11	12	12.7	14	15	15.875	16	19	-	-	95	130	115	5	M8x18	28	40
110A	11	12	12.7	14	15	15.875	16	19	-	-	110	130	115	5	M8x18	28	40
110A1	11	12	12.7	14	15	15.875	16	19	22	24	110	130	115	6.5	M8x20	38	50
110B	11	12	12.7	14	15	15.875	16	19	22	24	110	145	120	6.5	M8x20	38	50
110B1	11	12	12.7	14	15	15.875	16	19	22	24	110	145	120	6.5	M8x20	48	60
130A	11	12	12.7	14	15	15.875	16	19	22	24	130	165	140	6.5	M10x20	38	50
130A1	11	12	12.7	14	15	15.875	16	19	22	24	130	165	140	6.5	M10x25	48	60

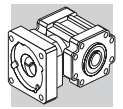

KR 30... H

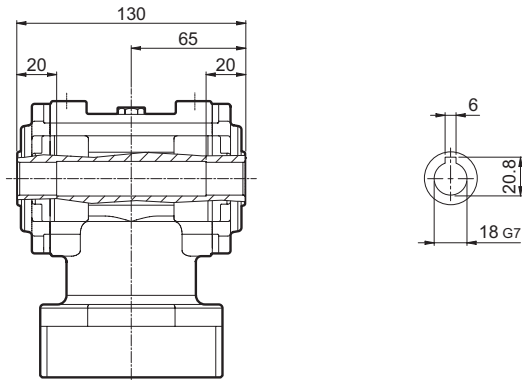

KR 30... HF

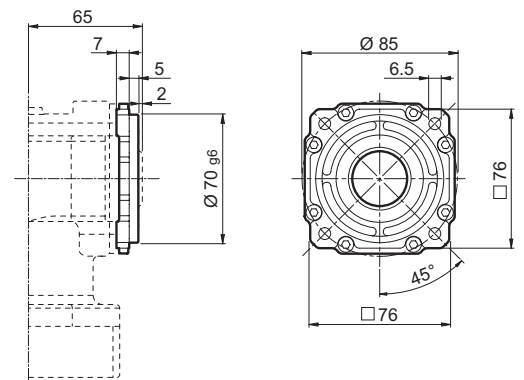

KR 30... S

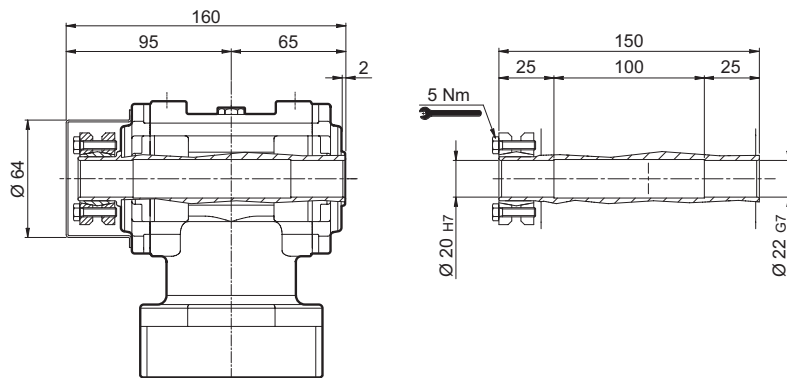

KR 30... SF

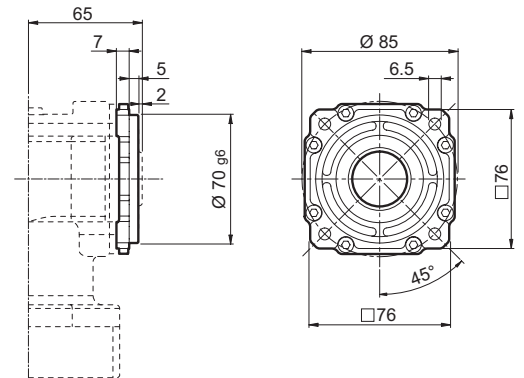

KR 30... LP

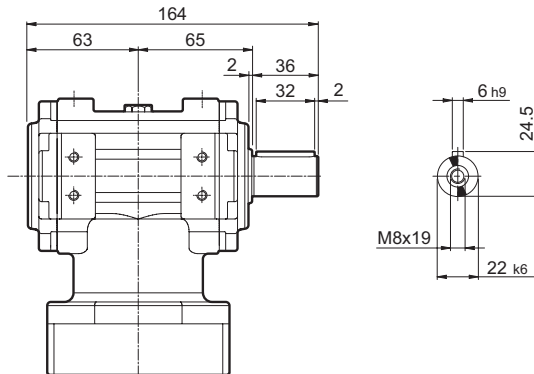

KR 30... LPF

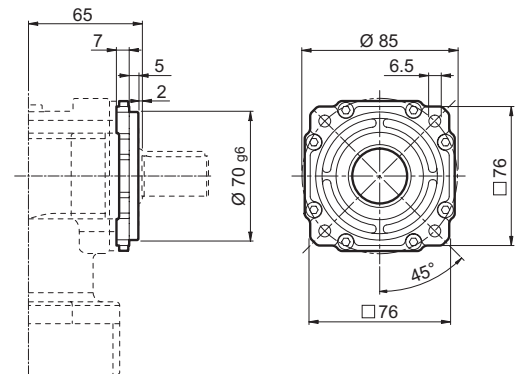

KR 30... LD

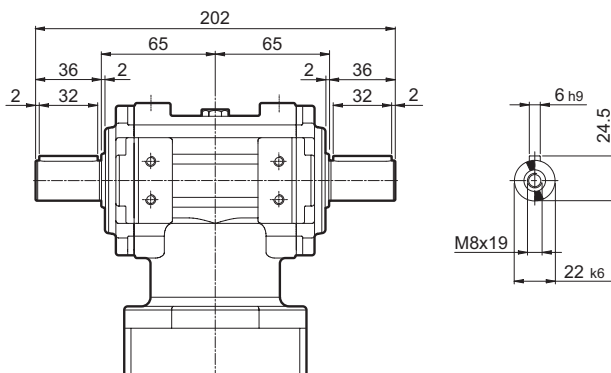

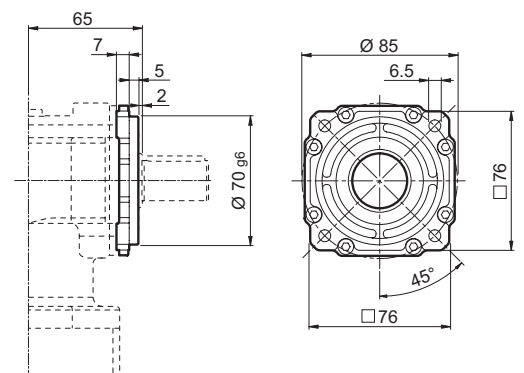

KR 30... LDF

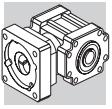

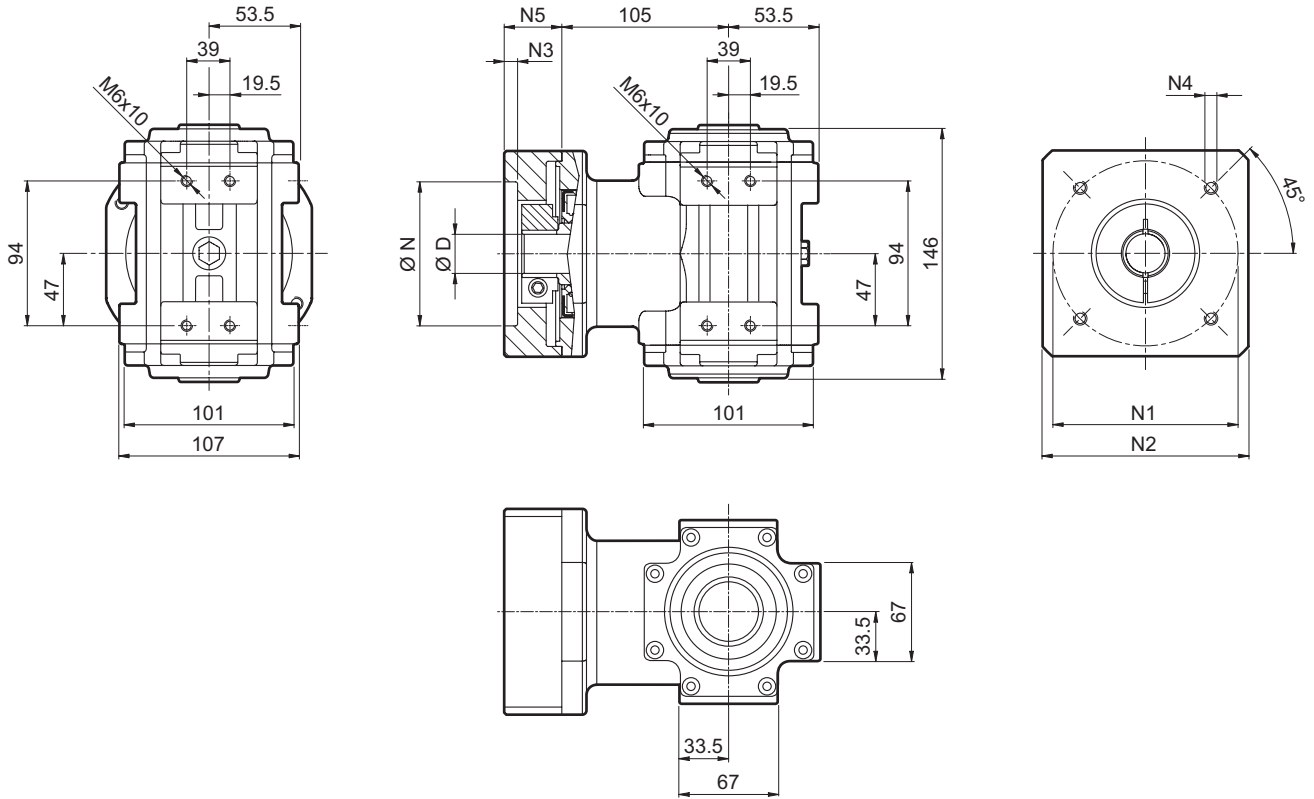

KR 40

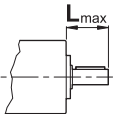

								N	N1	N2	N3	N4	N5	
55A	14	15.875	16	19	-	-	-	55.5	125.7	130	4	M6x15	39.5	50
80A	14	15.875	16	19	-	-	-	80	100	130	4	M6x15	39.5	50
95A	14	15.875	16	19	22	24	-	95	115	130	4	M8x20	39.5	50
110A	14	15.875	16	19	22	24	-	110	130	130	4	M8x20	39.5	50
110B	14	15.875	16	19	22	24	-	110	145	130	6.5	M8x20	49.5	60
114A	14	15.875	16	19	22	24	28	114.3	200	170	5.5	M12x25	69.5	80
130A	14	15.875	16	19	22	24	-	130	165	140	4	M10x20	39.5	50
130A1	14	15.875	16	19	22	24	28	130	165	140	4	M10x20	49.5	60
180A	14	15.875	16	19	22	24	28	180	215	190	5.5	M14x25	49.5	60
180A1	14	15.875	16	19	22	24	28	180	215	190	5.5	M14x25	69.5	80

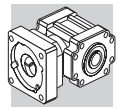

KR 40... H

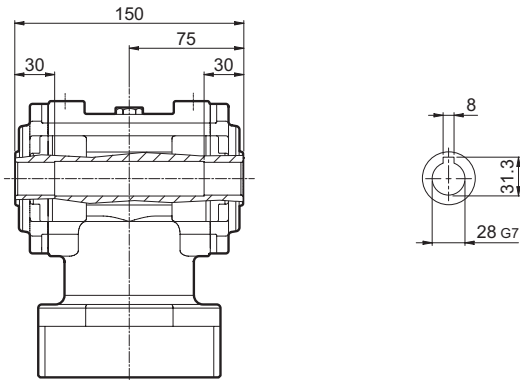

KR 40... HF

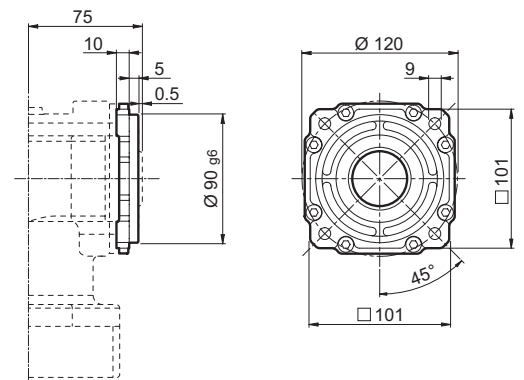

KR 40... S

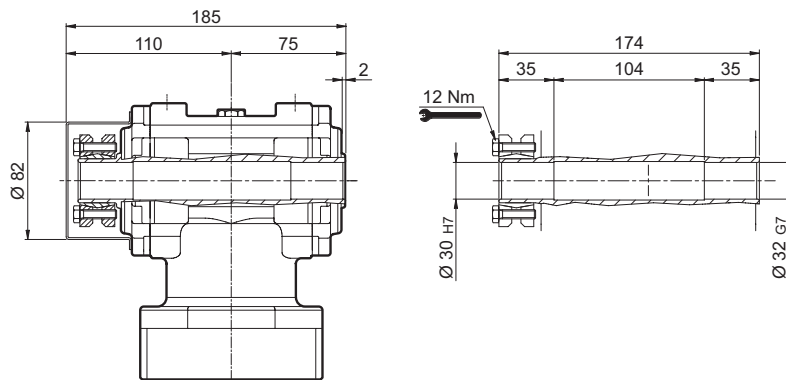

KR 40... SF

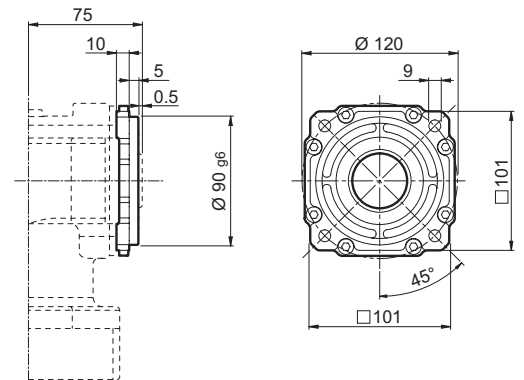

KR 40... LP

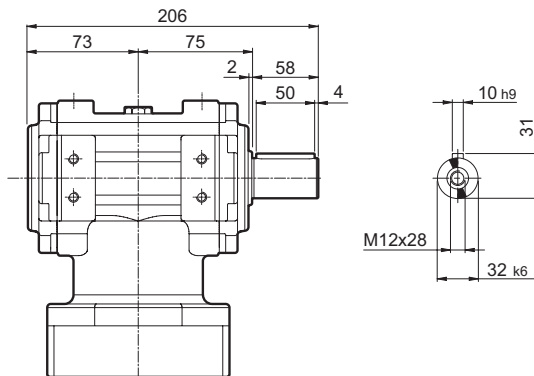

KR 40... LPF

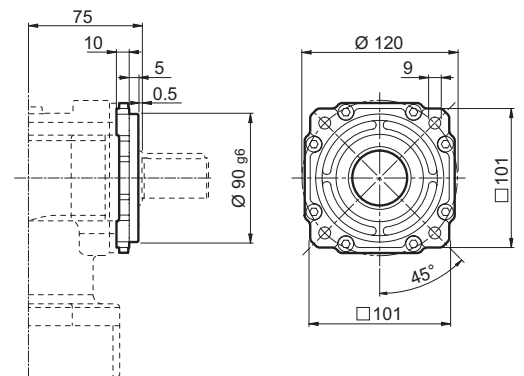

KR 40... LD

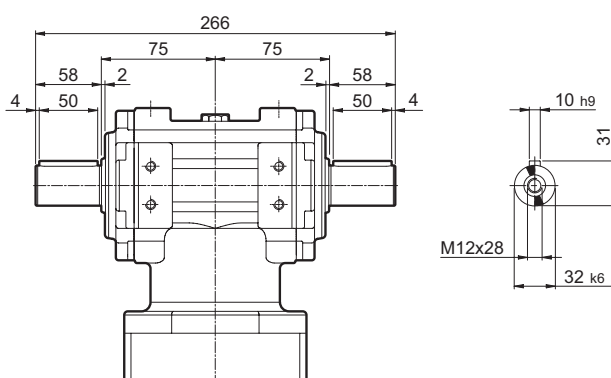

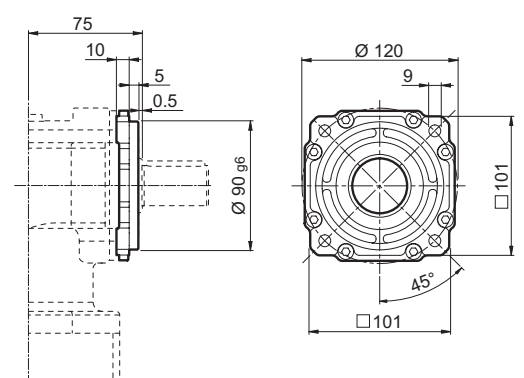

KR 40... LDF

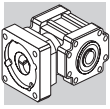

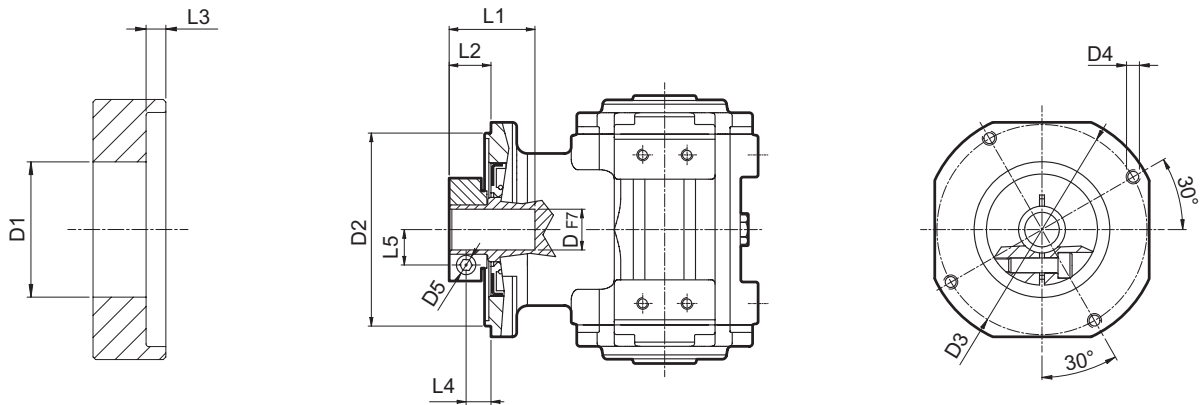

4.1 GEARBOX WITHOUT MOTOR ADAPTER - FM

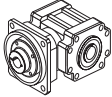
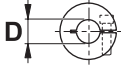

		D1	D2	D3	D4	D5	L1	L2	L3	L4	L5	
KR 10	6 6.35 7	32.5	50	42.5	M4x8	M4	28	13.5	3	8.5	8	1.0
	8 9 9.52 10	32.5	50	42.5	M4x8	M4	28	13.5	3	8.5	9	
	11 12 12.7	35.5	50	42.5	M4x8	M4	23	13.5	3	8.5	11	
	14	35.5	50	42.5	M4x8	M4	23	13.5	3	8.5	11.5	
KR 20	8 9 9.52	38	68	76.5	M6x10	M6	36.3	26.3	9.5	18.8	10.5	2.0
	11 12 12.7	43	68	76.5	M6x10	M6	36.3	26.3	9.5	18.8	12.5	
	14 15.875 16 17	48	68	76.5	M6x10	M6	36.3	26.3	9.5	18.8	14.5	
	19 19.05	51	68	76.5	M6x10	M6	36.3	26.3	9.5	18.8	16.5	
KR 30	11 12 12.7	43	90	98	M6x15	M6	35	19.5	7.6	12.1	12.5	3.5
	14 15 15.875 16	48	90	98	M6x15	M6	35	19.5	7.6	12.1	14.5	
	19	51	90	98	M6x15	M6	35	19.5	7.6	12.1	16.5	
	22 24	56.5	90	98	M6x15	M6	37	21.5	7.6	12.1	19	
KR 40	14 15.875 16	48	113	125.5	M8x15	M6	46	27.5	6	20	14.5	10.0
	19	51	113	125.5	M8x15	M6	46	27.5	6	20	16.5	
	22 24	56.5	113	125.5	M8x15	M6	47.5	29	6	20	19	
	28	67	113	125.5	M8x15	M8	47.5	29	6	20	22.5	

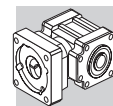



4.2 MACHINE SHAFT

Pivot of driven equipment should be made from high grade alloy steel. Table below shows recommended dimensions for the Customer to consider when designing mating shaft. A device retaining the shaft axially is also recommended (not shown). The number and size of relative tapped holes at shaft end depend on application requirements.

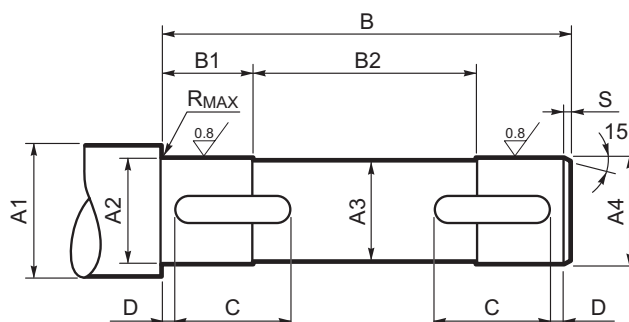
H

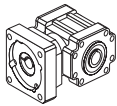

	A1	A2	A3	A4	B	B1	B2	C	D	R _{MAX}	 UNI 6604	S
KR 30	≥ 26	18 h7	17	18 h7	129	18	90	32	2	0.5	6x6x25 A	1
KR 40	≥ 36	28 h7	27	28 h7	149	28	90	50	2	0.5	8x7x35 A	

S

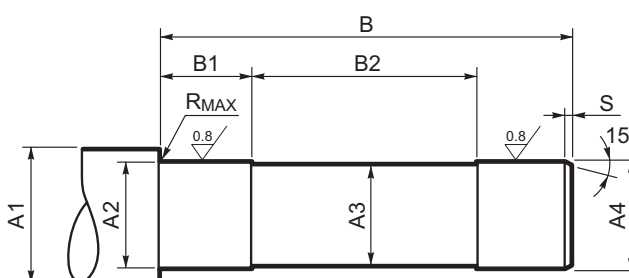

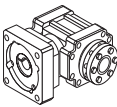
	A1	A2	A3	A4	B	B1	B2	R _{MAX}	S
KR 10	≥ 15	11 h7	9.5	10 h6	99	13	70	0.5	1
KR 20	≥ 20	16 h7	14.5	15 h6	122	18	83	0.2	
KR 30	≥ 30	22 h7	19.5	20 h6	149	23	100	0.5	
KR 40	≥ 40	32 h7	29.5	30 h6	173	33	104	0.5	

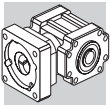

INDEX OF REVISIONS (R)

R2	
	Description
	The specifications formerly corresponding to option DH are now integrated as a standard product configuration
10 12 14 16	Chapter 4 "Dimensions": - harmonized the code number for some of the input adapters - dropped availability of hollow output shaft, H and HF type, for KR 20

090406

This publication supersedes and replaces any previous edition and revision. We reserve the right to implement modifications without notice. This catalogue cannot be reproduced, even partially, without prior consent.

KR



www.tecnoingranaggi.it

TECNOINGRANAGGI

TECNOINGRANAGGI RIDUTTORI s.r.l.
Via Davia, 5
40017 S. Giovanni in Persiceto
Bologna (ITALY)
Tel. (+39) 0516878111
Fax (+39) 0516878132
www.tecnoingranaggi.it
info@tecnoingranaggi.it